

**Doers Window**  
MANUFACTURING  
4901 Oak Fair Blvd., Tampa, FL 33610

# 9500 Slider XO

## IMPACT RATED

### w/ Flange

#### GENERAL NOTES

1. This product anchoring drawing has been evaluated and is in compliance with the 5th Edition (2014) Florida Building Code (FBC) excluding the "High Velocity Hurricane Zone" (HVHZ). See the Certification Agency Certificate for sizes, specifications & ratings.
2. Product anchors shall be as listed and spaced as shown on details. Anchor embedment to base material shall be beyond wall dressing or stucco.
3. When used in areas requiring wind borne debris protection, this product complies with Section 1609.1.2 of the FBC and does not require an impact resistant covering. This product meets missile level "D" and includes Wind Zone 4 as defined in ASTM E 1996 and Section 1609.1.2.2 of the FBC.
4. For 2x stud framing construction, anchoring of these units shall be the same as that shown for 2x buck masonry construction.
5. Site conditions that deviate from the details of this drawing require further engineering analysis by a licensed engineer or registered architect.

TABLE OF CONTENTS	
SHEET#	DESCRIPTION
1	Typical elevations, design pressures & general notes
2	Vertical & horizontal cross sections
3	Buck & frame anchoring
4	Components
5	Bill of materials and glazing details

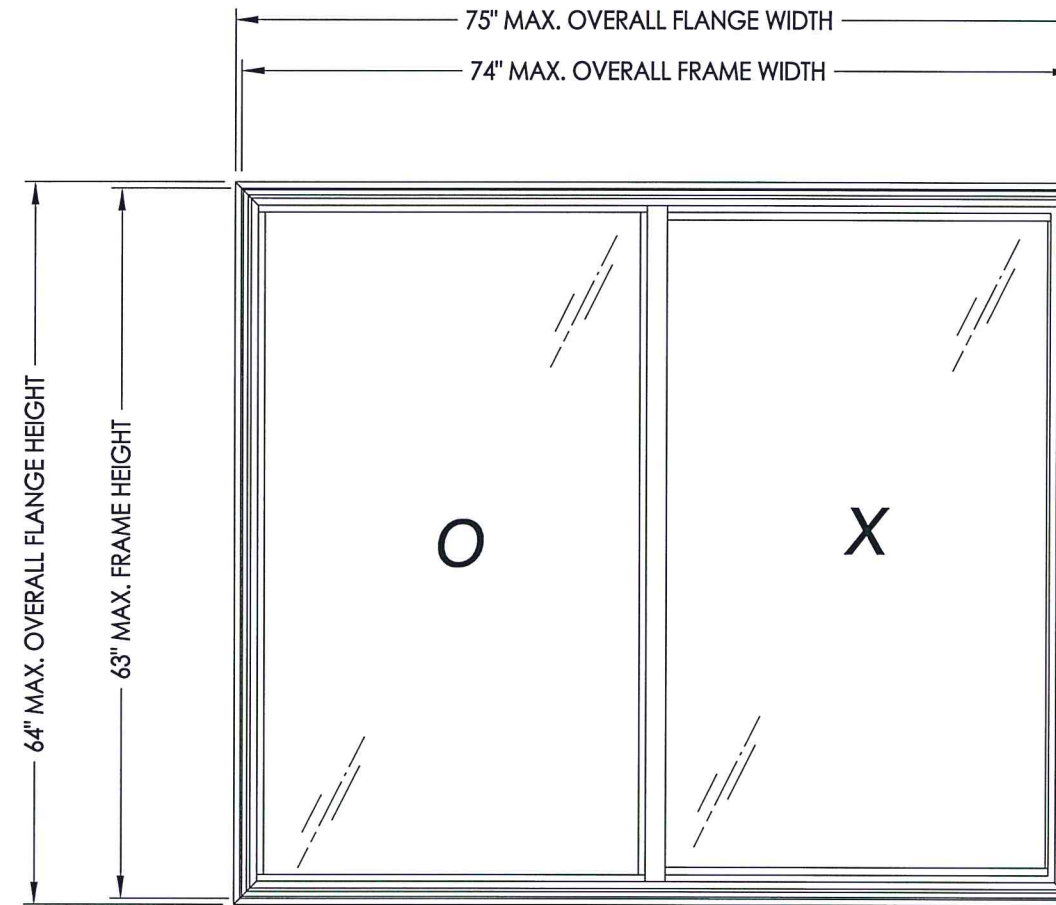

MAX. OVERALL FLANGE DIMENSION	MAX. OVERALL FRAME DIMENSION	MAX DAY LITE DIMENSION (OPERABLE)	MAX DAY LITE DIMENSION (FIXED)	GLASS TYPE	DESIGN PRESSURE (PSF)	
					POS.	NEG.
75.0" X 64.0"	74.0" X 63.0"	33.5" X 57.31"	33.25" X 58.56"	G1	+50.0	-60.0

Documents Prepared By: *RW*  
 Lyndon F. Schmidt  
 P.E. No. 43409

*RW* BUILDING CONSULTANTS, INC.  
 P.O. Box 230, Valrico, FL 33595  
 Phone No.: 813.659.9197  
 FBPE C.A. No. 9813

PRODUCT: Doers  
 PART OR ASSEMBLY: TYPICAL ELEVATION, DESIGN PRESSURES & GENERAL NOTES

NO.	DATE	REVISIONS
1	6/25/15	UPDATE TO 5TH ED. (2014) FBC

DATE: 2/19/14  
 SCALE: N.T.S.  
 DWG. BY: JK  
 CHK. BY: LFS  
 DRAWING NO.: FL-16853.4  
 SHEET 1 OF 5

R:\Clients\Doors PERMANENT\A - Florida Product Approval\EL-16853 Windows - Horizontal Sliders\C - Drawings\EL-16853-1-6.dwg\_2 4

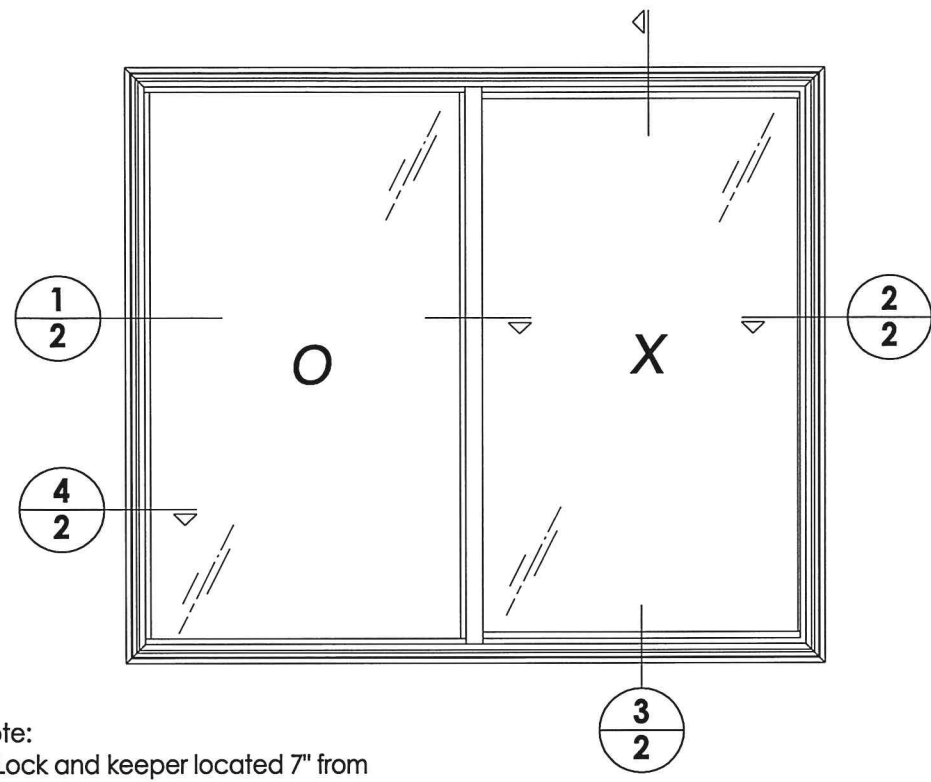

- Note:
1. Lock and keeper located 7" from each end of lock/meeting stile.
  2. Metal roller assembly located 2" from each end of the bottom rail.
  3. Anti-lift secured to head with (6) #6 x 1/2" PPH SMS.

NOTE: Sheet Metal Screws must penetrate a min. of 3 threads through at least 2 sheets of metal (maintain a min. 3/8" edge distance).

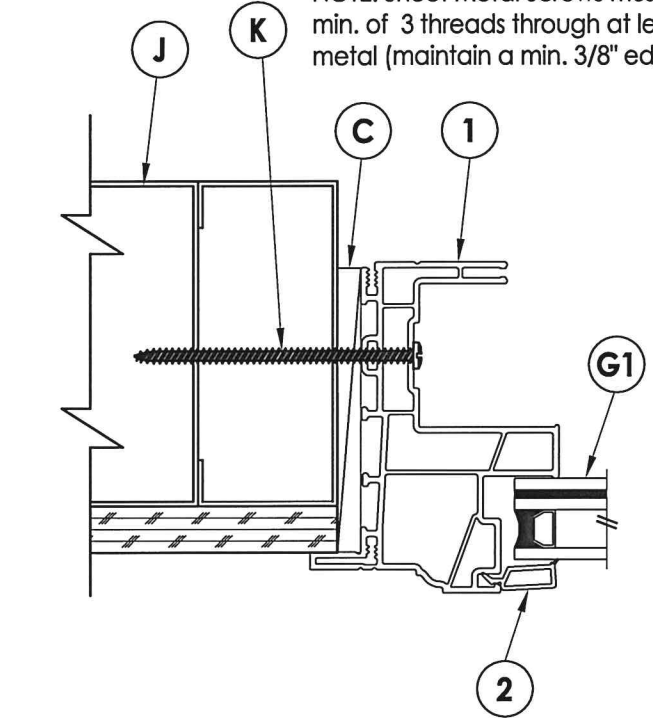

**4** HORIZONTAL CROSS SECTION  
**2** Metal Stud Construction

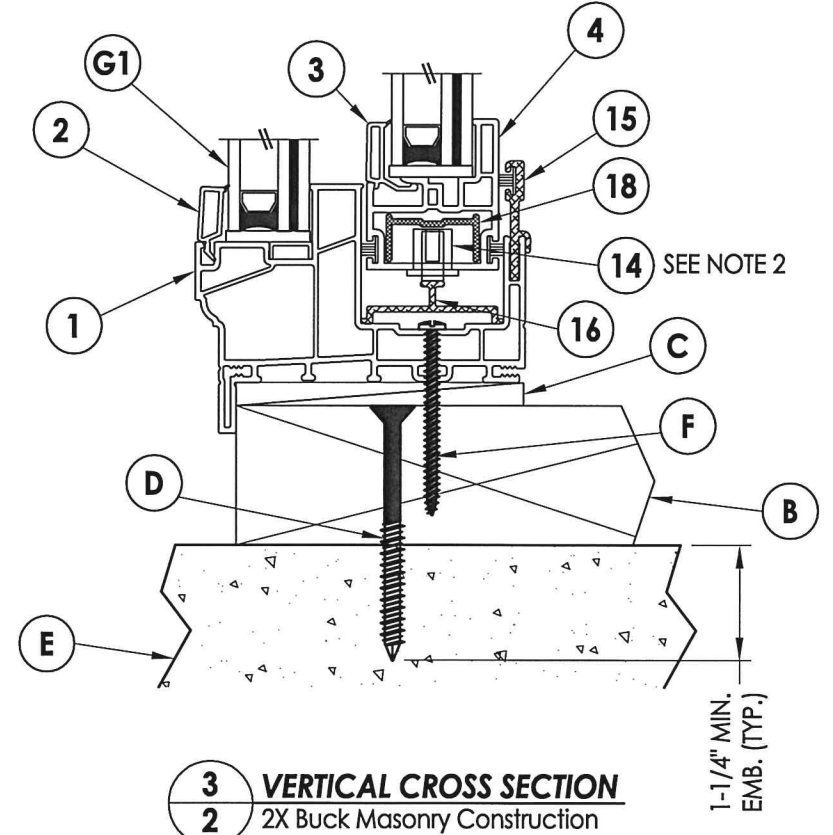
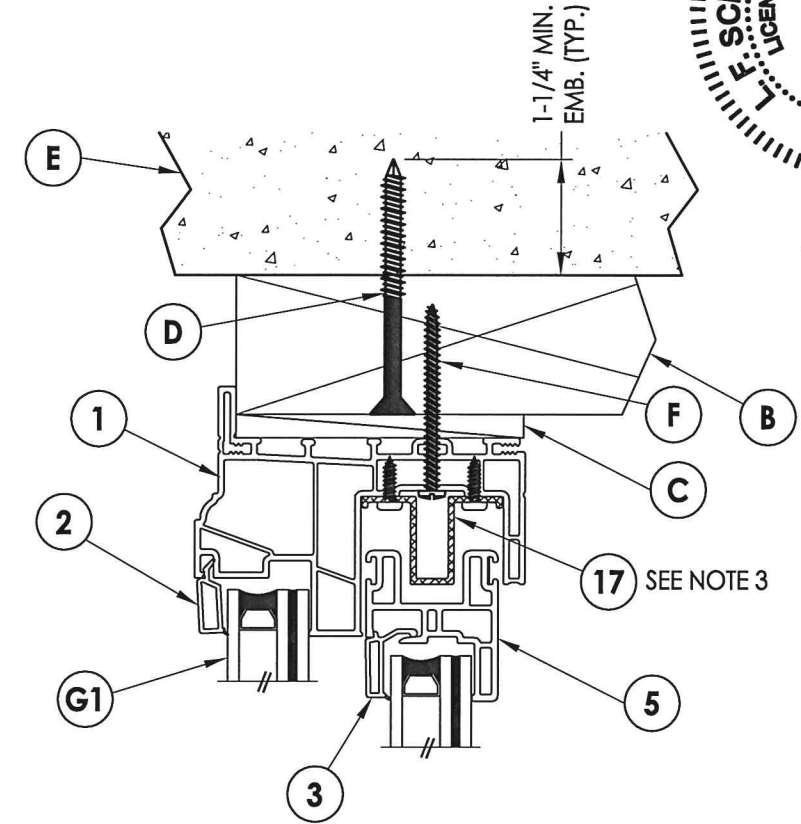

**3** VERTICAL CROSS SECTION  
**2** 2X Buck Masonry Construction

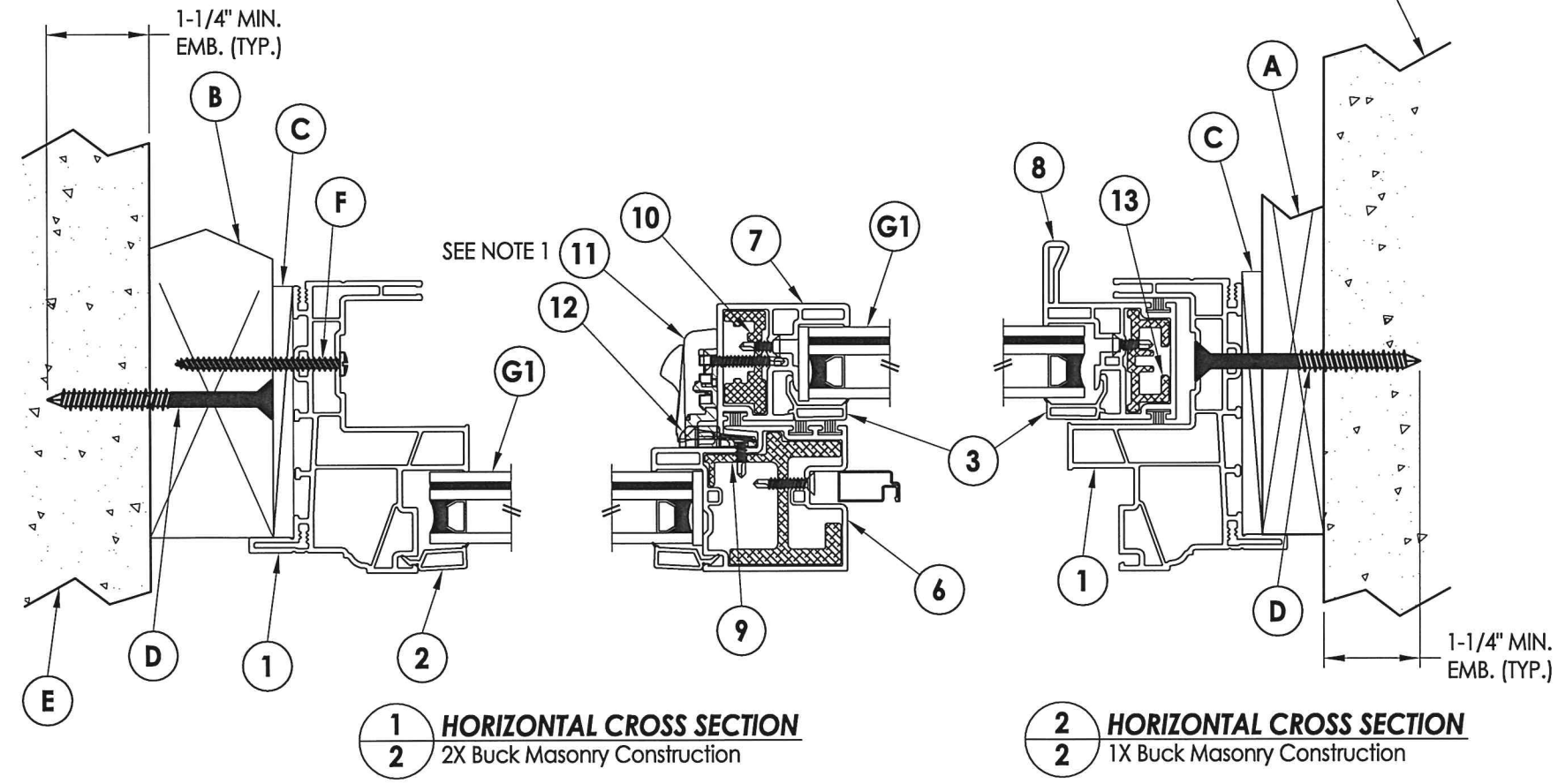

**1** HORIZONTAL CROSS SECTION  
**2** 2X Buck Masonry Construction

**2** HORIZONTAL CROSS SECTION  
**2** 1X Buck Masonry Construction

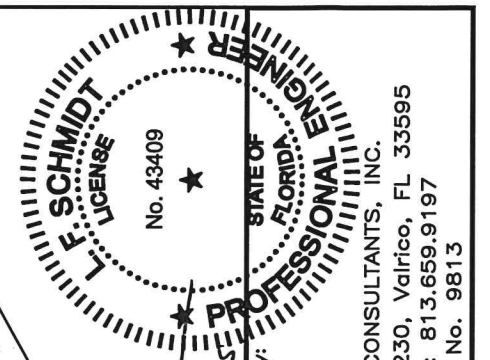

Documents Prepared By:  
Lyndon F. Schmidt  
P.E. No. 43409

RW BUILDING CONSULTANTS, INC.  
P.O. Box 230, Valrico, FL 33595  
Phone No.: 813.659.9197  
FBPE C.A. No. 9813

PRODUCT:	Doors	
PART OR ASSEMBLY:	VERTICAL & HORIZONTAL CROSS SECTIONS	
DATE:	2/19/14	
SCALE:	N.T.S.	
DWG. BY:	JK	
CHK. BY:	LFS	
DRAWING NO.:	FL-16853.4	
SHEET	2 OF 5	
NO.	DATE	BY
1	6/25/15	UPDATE TO 5TH ED. (2014) FBC
REVISIONS		

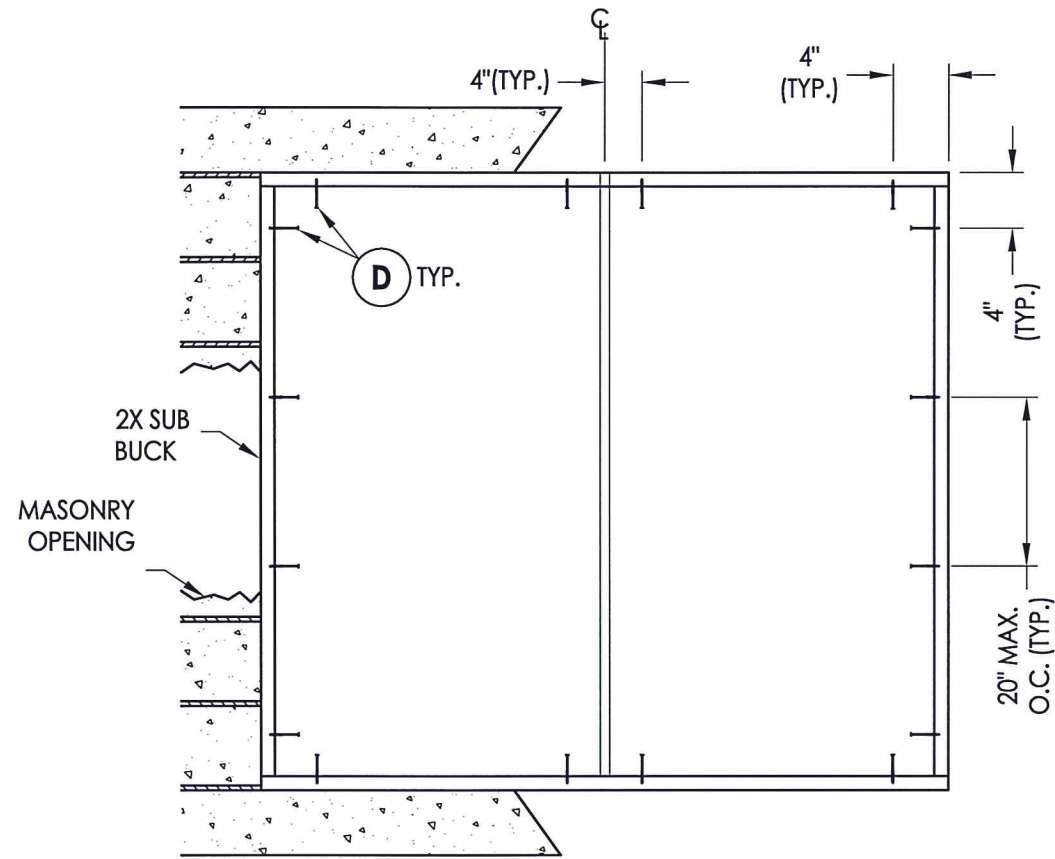

**2X BUCK ANCHORING**

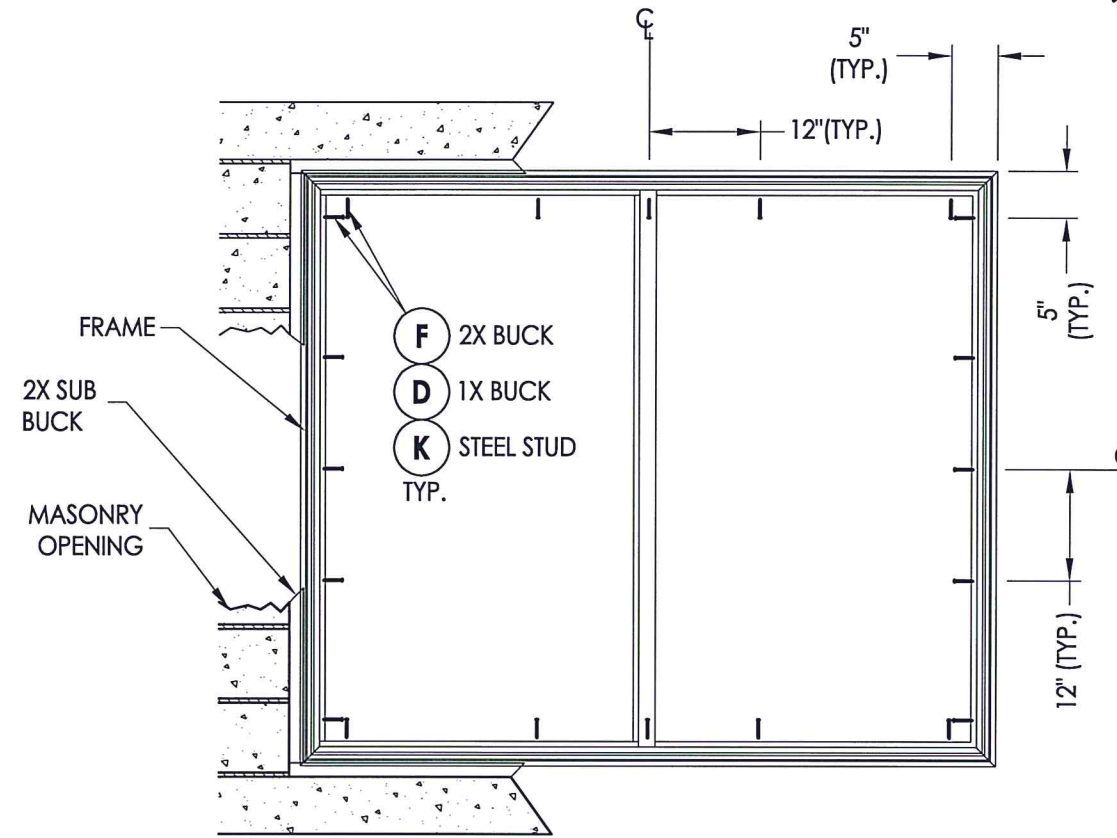

**FRAME ANCHORING**

**CONCRETE ANCHOR NOTES:**

- Concrete anchor locations at the corners may be adjusted to maintain the min. edge distance to mortar joints.
- Concrete anchor locations noted as "MAX. ON CENTER" must be adjusted to maintain the min. edge distance to mortar joints, additional concrete anchors may be required to ensure the "MAX. ON CENTER" dimension are not exceeded.
- Concrete anchor table:

ANCHOR TYPE	ANCHOR SIZE	MIN. EMBEDMENT	MIN. CLEARANCE TO MASONRY EDGE	MIN. CLEARANCE TO ADJACENT ANCHOR
ITW TAPCON®	1/4"	1-1/4"	2"	4"
ELCO ULTRACON®	1/4"	1-1/4"	1"	4"

**WOOD SCREW INSTALLATION NOTES:**

- Maintain a minimum 5/8" edge distance, 1" end distance, & 1" o.c. spacing of wood screws to prevent the splitting of wood.

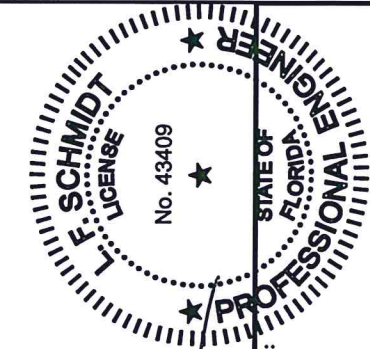

Documents Prepared By:  
Lyndon F. Schmidt  
P.E. No. 43409

**RW** BUILDING CONSULTANTS, INC.  
P.O. Box 230, Valrico, FL 33595  
Phone No.: 813.659.9197  
FBPE C.A. No. 9813

PRODUCT:	Doers
PART OR ASSEMBLY:	BUCK & FRAME ANCHORING
DATE:	2/19/14
SCALE:	N.T.S.
DWG. BY:	JK
CHK. BY:	LFS
DRAWING NO.:	FL-16853.4
SHEET	3 OF 5

NO.	DATE	REVISIONS
1	6/25/15	UPDATE TO 5TH ED. (2014) FBC

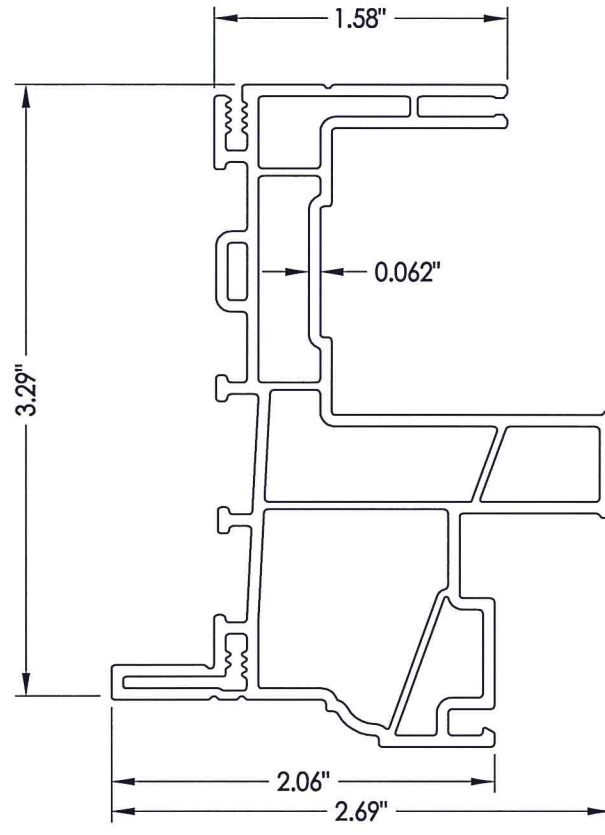

**1** FRAME

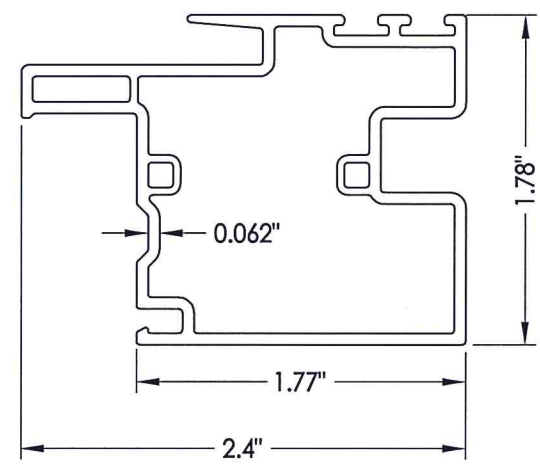

**6** MEETING STILE

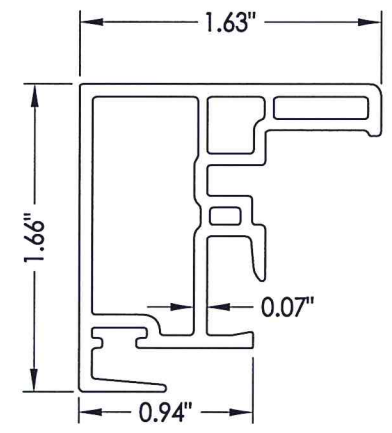

**7** LOCK STILE

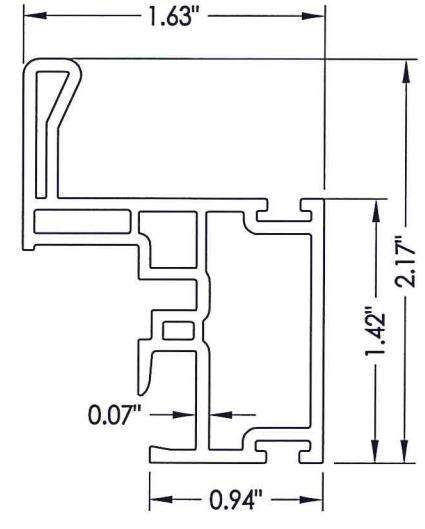

**8** HANDLE STILE

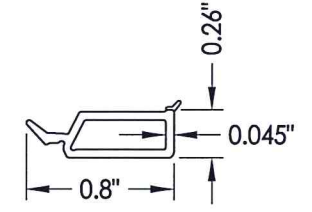

**2** GLAZING BEAD

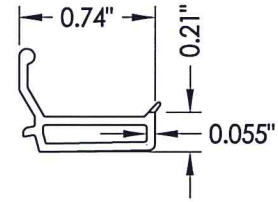

**3** GLAZING BEAD

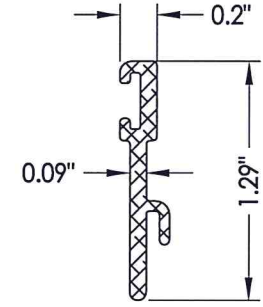

**15** SILL RISER

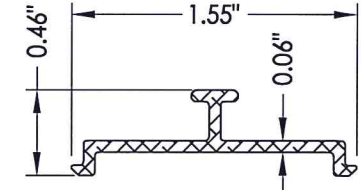

**16** ROLLER TRACK

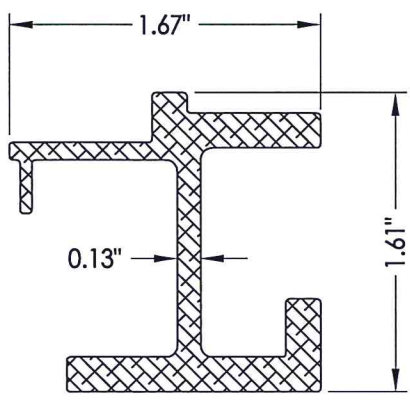

**9** MEETING STILE REINFORCEMENT

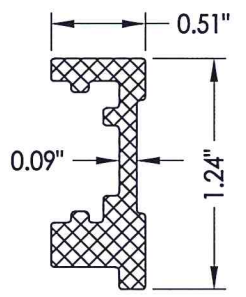

**10** LOCK STILE REINFORCEMENT

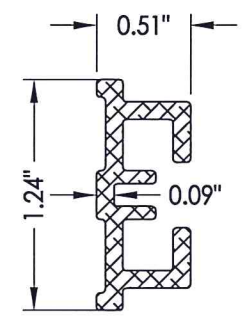

**13** HANDLE STILE REINFORCEMENT

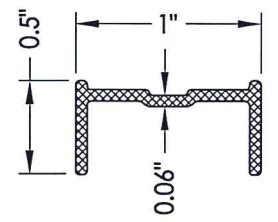

**18** BOTTOM RAIL REINFORCEMENT

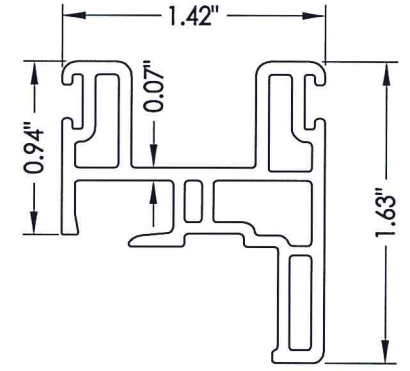

**5** TOP RAIL

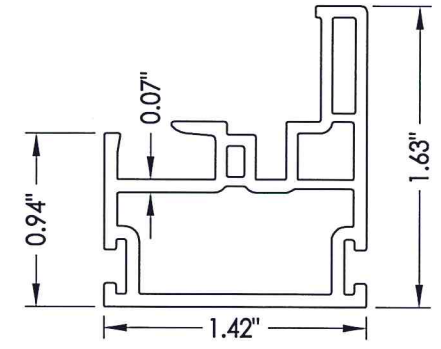

**4** BOTTOM RAIL

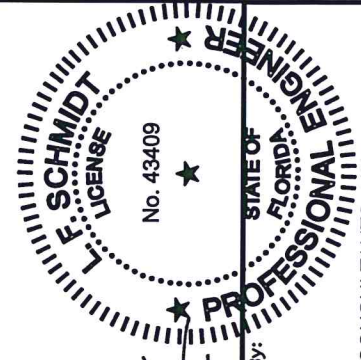

*LFS*  
*7.1.15*

Documents Prepared By:  
Lyndon F. Schmidt  
P.E. No. 43409

**RW** BUILDING CONSULTANTS, INC.  
P.O. Box 230, Valrico, FL 33595  
Phone No.: 813.659.9197  
FBPE C.A. No. 9813

PRODUCT: Doers		PART OR ASSEMBLY: COMPONENTS	
NO.	DATE	BY	REVISIONS
1	6/25/15	LFS	UPDATE TO 5TH ED. (2014) FBC
DATE: 2/19/14		SCALE: N.T.S.	
DWG. BY: JK		CHK. BY: LFS	
DRAWING NO.: FL-16853.4			
SHEET 4 OF 5			

R:\Clients\Doers PERMANENT\Florida Product Approvals\FL-16853 Windows - Horizontal Sliders\C - Drawings\FL-16853.1-6.dwg, 5.4

BILL OF MATERIALS		
ITEM #	DESCRIPTION	MATERIAL
B	2X BUCK (SG >= 0.42)	WOOD
C	1/4" MAX. SHIM SPACE	-
D	1/4" X 2-3/4" PFH ELCO OR ITW CONCRETE SCREW	STEEL
E	MASONRY - 3,000 PSI MIN. CONCRETE CONFORMING TO ACI 301 OR HOLLOW BLOCK CONFORMING TO ASTM C90	CONCRETE
F	#10 X 2" PPH SMS (1-1/4" MIN. EMBEDMENT)	STEEL
J	STEEL STUD Min. Thk .033" (ASTM A653 GRADE 33 Fy=33 ksi min., Fu=45 ksi min.)	STEEL
K	#10 PPH SELF-DRILLING SMS	STEEL
1	EXTRUDED VINYL FRAME (439)*	RIGID PVC
2	EXTRUDED VINYL GLAZING BEAD (736A)*	RIGID PVC
3	EXTRUDED VINYL GLAZING BEAD (425A) *	RIGID PVC
4	BOTTOM RAIL (424B)*	RIGID PVC
5	TOP RAIL (478)*	RIGID PVC
6	MEETING STILE (477)*	RIGID PVC
7	LOCK STILE (476)*	RIGID PVC
8	HANDLE STILE (475B)*	RIGID PVC
9	MEETING STILE REINFORCEMENT	6063 - T5 ALUM
10	LOCK STILE REINFORCEMENT	6063 - T5 ALUM
11	SASH LOCK	-
12	KEEPER	-
13	HANDLE STILE REINFORCEMENT	6063 - T5 ALUM
14	ROLLER (TRUTH #2433-1000)	-
15	SILL RISER	6063 - T5 ALUM
16	ROLLER TRACK	6063 - T5 ALUM
17	ANTI-LIFT ALUMINUM	6063 - T5 ALUM
18	BOTTOM RAIL REINFORCEMENT	6063 - T5 ALUM
20	WEATHERSTRIP (.187" X .290")	-

\* THE APPROVED WHITE RIGID PVC EXTERIOR EXTRUSIONS FOR WINDOWS ARE TO BE PRODUCED BY EXTRUDERS LICENSEES IN "AAMA CERTIFICATION PROGRAMS FOR RIGID PVC EXTRUSIONS".

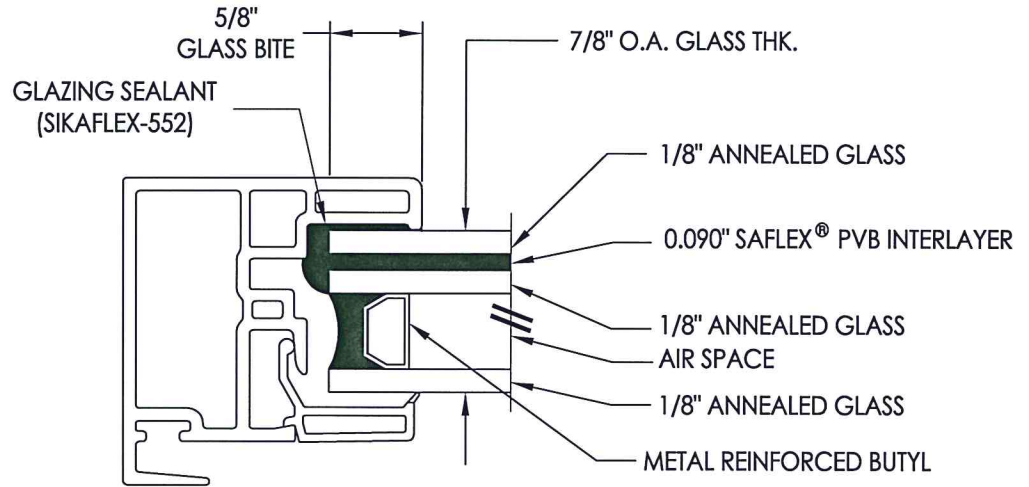

**G1** GLAZING DETAIL

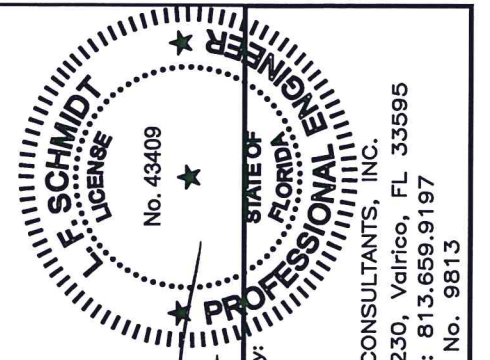

*LFS*  
*7.1.15*

Documents Prepared By:  
Lyndon F. Schmidt  
P.E. No. 43409

**RW** BUILDING CONSULTANTS, INC.  
P.O. Box 230, Valrico, FL 33595  
Phone No.: 813.659.9197  
FBPE C.A. No. 9813

PRODUCT:	Doers	
PART OR ASSEMBLY:	BILL OF MATERIALS AND GLAZING DETAILS	
NO.	DATE	BY
1	6/25/15	LFS
UPDATE TO 5TH ED. (2014) FBC		
REVISIONS		
DATE: 2/19/14		
SCALE: N.T.S.		
DWG. BY: JK		
CHK. BY: LFS		
DRAWING NO.: FL-16853.4		
SHEET 5 OF 5		